

广西消防救援总队火灾救援物资储备库及被装 仓库自动化储存货架采购重采项目

项目编号：ZXJTZB2022-015

广西消防救援总队

采购项目

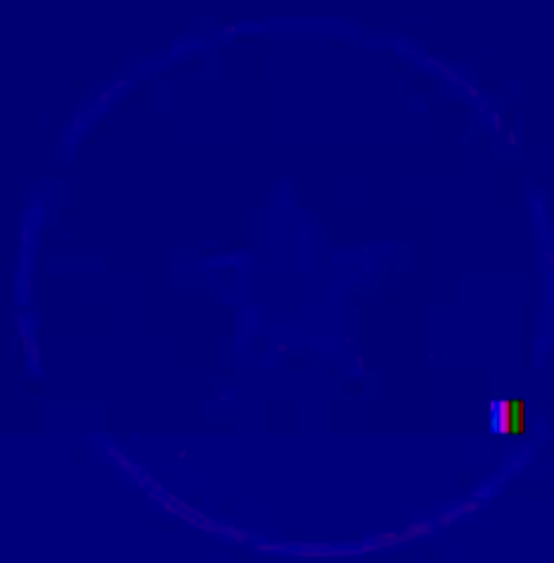

售价：每套250.00元，售后不退。如需邮购，每本另加邮费 50 元（邮购文件的，需于发件截止时随附寄书带及邮资证明贴于书袋）。

上海书店出版社（上海南京路103号）

上海书店出版社（上海南京路103号）

上海书店出版社（上海南京路103号）

上海书店出版社（上海南京路103号）

(4) 强制采购节能产品；优先采购节能产品、环境标志产品。

七、对本次招标提出询问，请按以下方式联系。

1. 招标人信息

名称：广西壮族自治区消防救援总队

地址：南宁市良庆区那黄大道19号

联系人：李俊 联系电话：0771-3860000

3. 采购代理机构

采购代理机构：广西



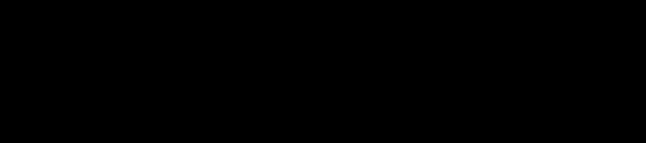

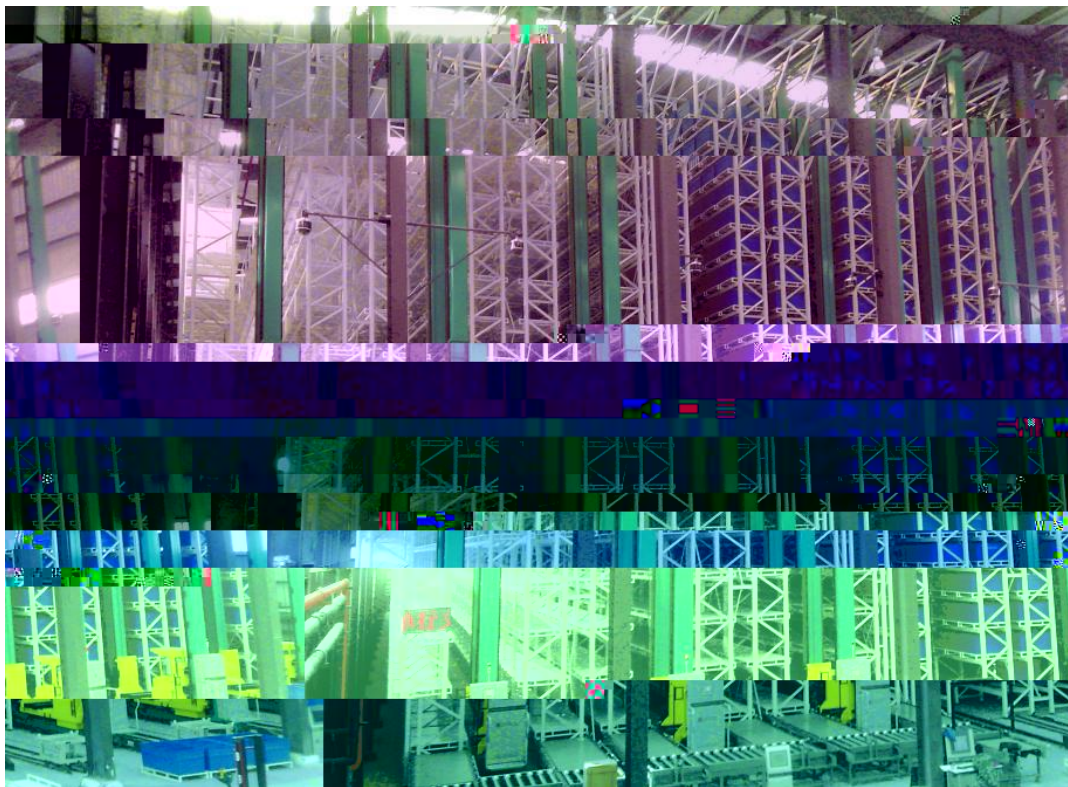

-
-
-
-
-

-
-
-
-
-

-
-
-
-
-
-

-
-
-



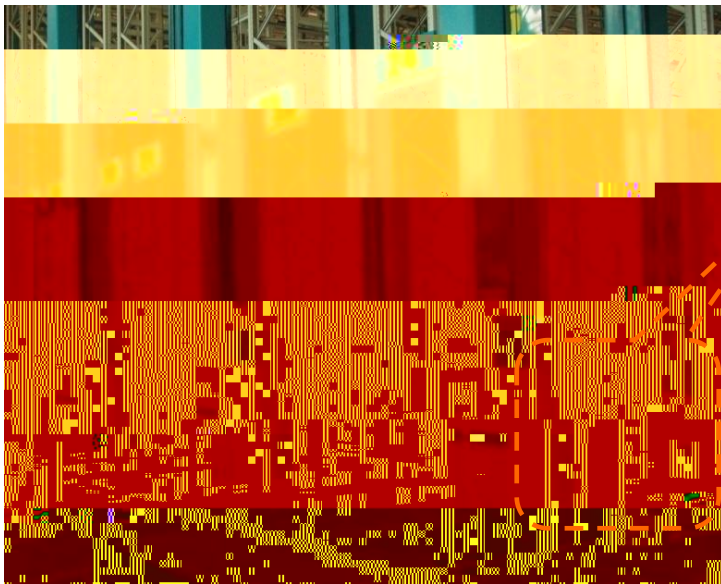
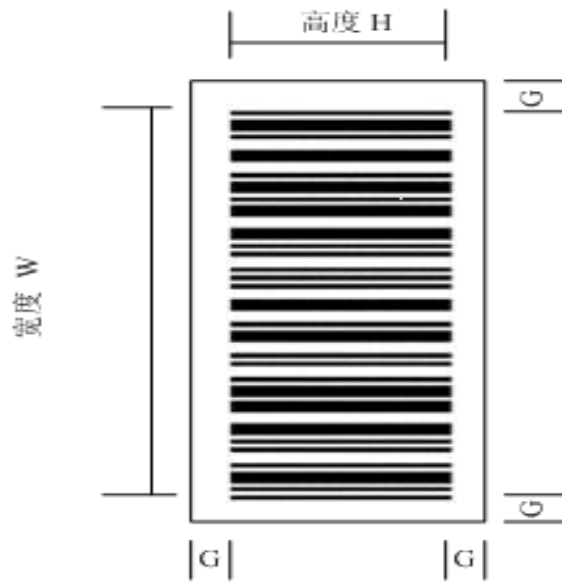

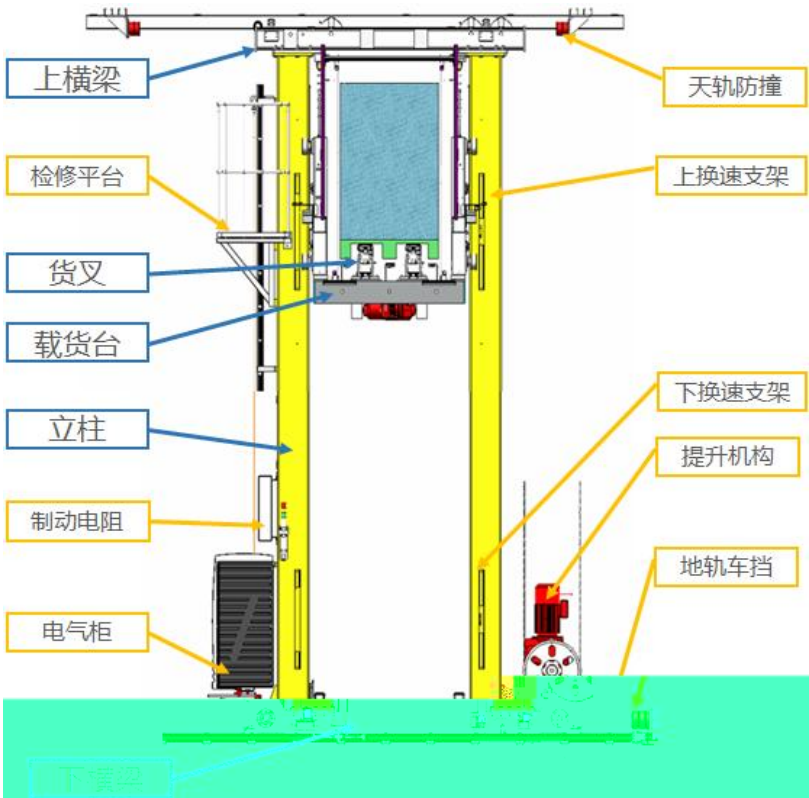

noway



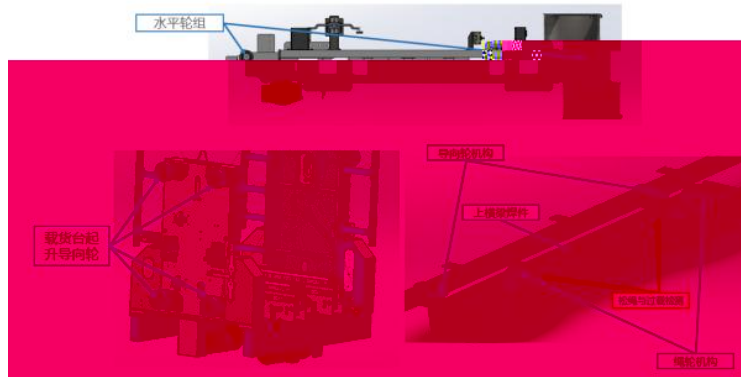
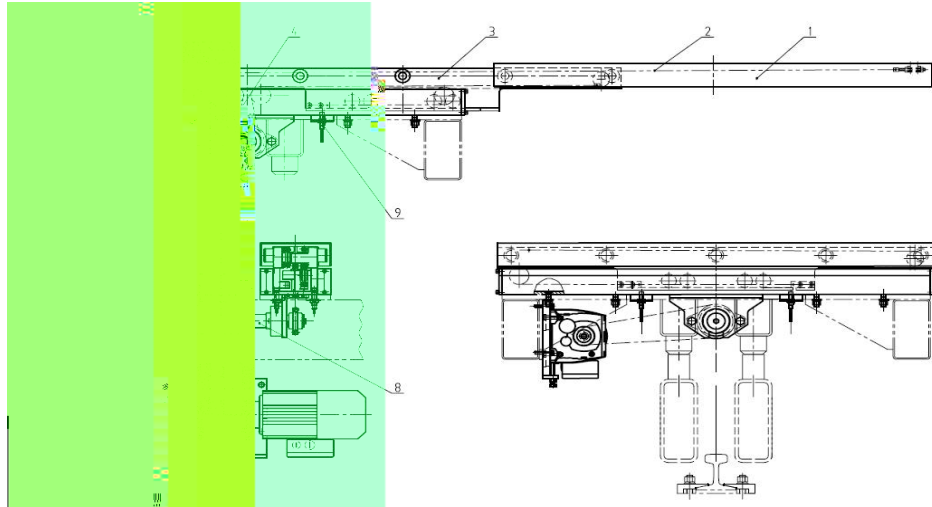









LED

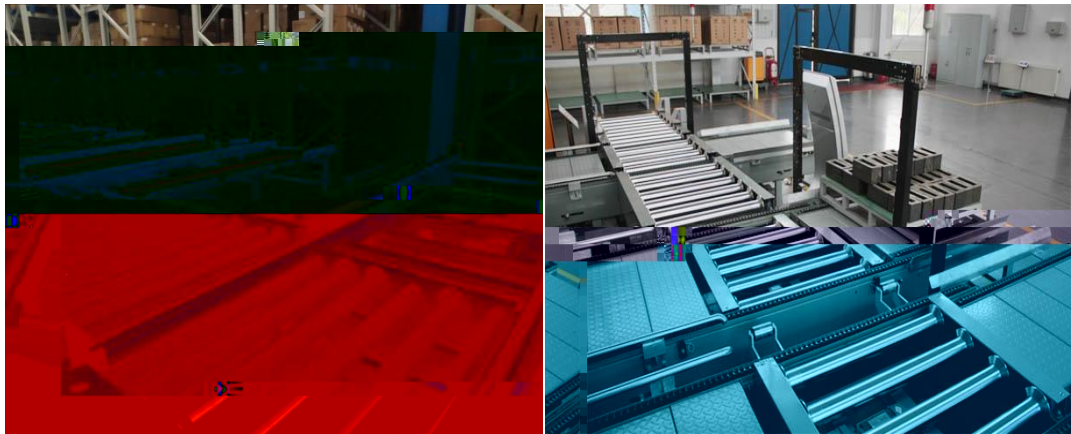

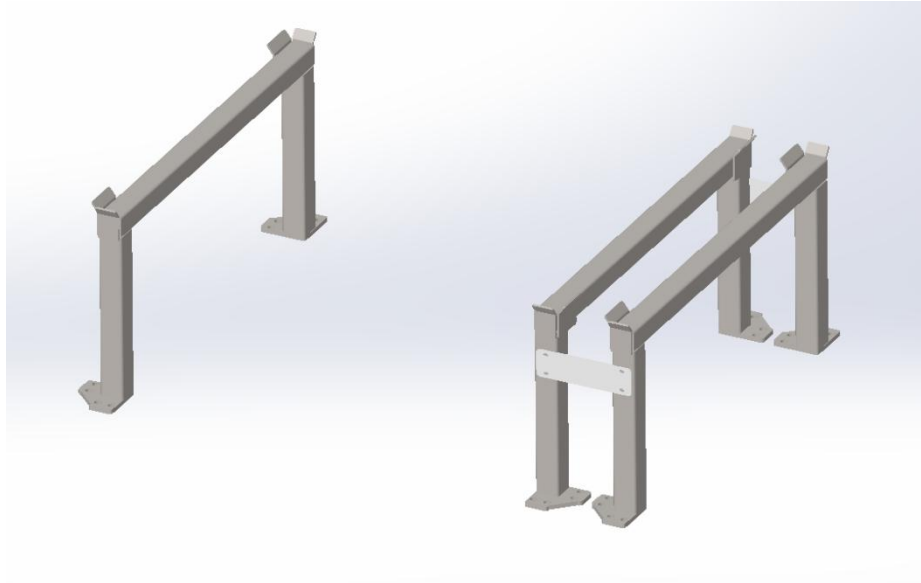

业务层

WMS系统



控制层

机器人调度系统 (RCS)



执行层

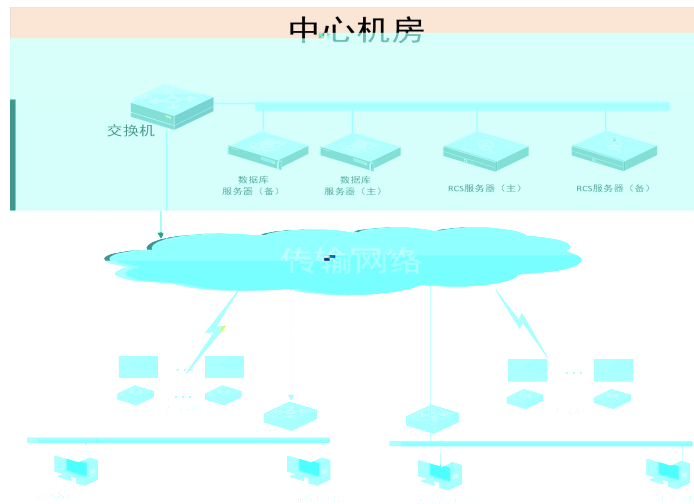

子系统	主要功能
系统配置	系统配置：包含设备配置，服务配置，地图配置，用户角色配置等
任务管理	任务配置：设置任务，如任务优先级，任务组
告警管理	告警管理：告警信息管理统计
日志管理	日志管理：用户操作日志管理
异常管理	异常管理：处理消息发送与接收的异常
设备管理	设备管理：与设备通信，收取设备实时状态
充电管理	充电管理：自动控制设备充电
路径规划	路径规划：包括拓扑/长方形栅格的路径规划
任务分配	任务分配：空闲小车任务分配
世界模型维护	世界模型维护：AGV运行地图的维护
任务管理	任务管理：记录任务执行阶段自动执行
通讯管理	通讯管理：AGV控制指令下发等
消息转发	消息转发：将告警信息转发到各个监控客户端
信息存储	信息存储：告警信息存储
地图展示	地图展示：运行地图显示，每个AGV在地图上的位置显示
地图控制	地图控制：通过控制设备移动，控制AGV运行
地图维护	地图维护：地图维护，如地图更新，地图删除等
地图管理	地图管理：地图管理，如地图权限，地图备份等
地图服务	地图服务：地图服务，如地图查询，地图更新等

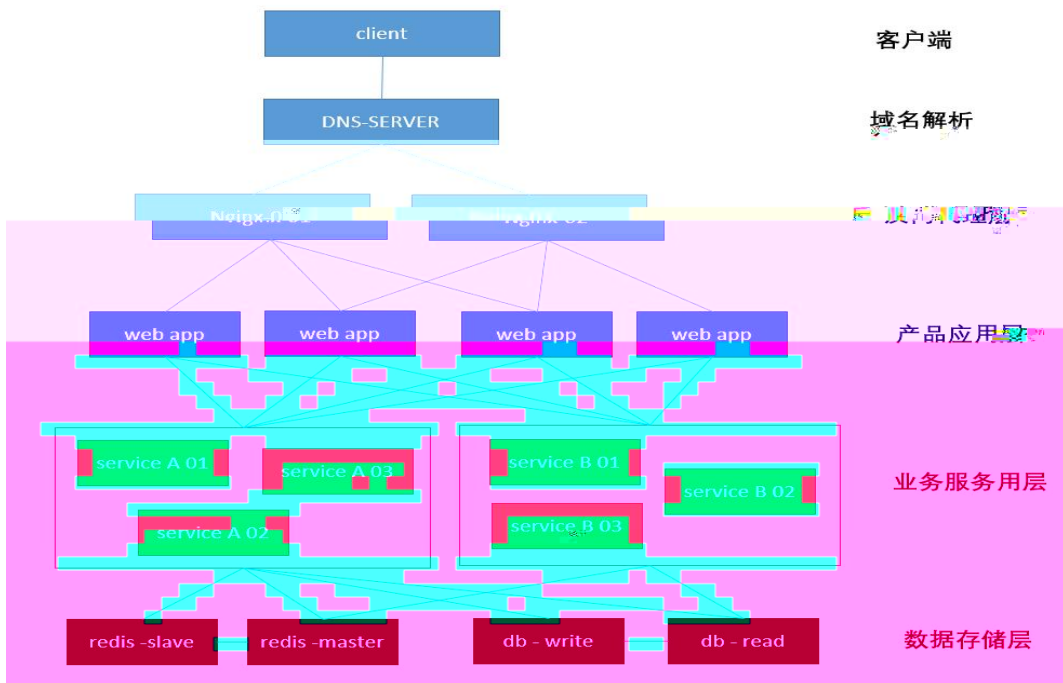





.)... 2... ..

VE

Györf

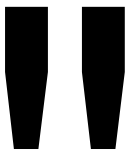
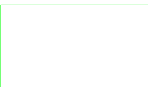

BAKÓ A









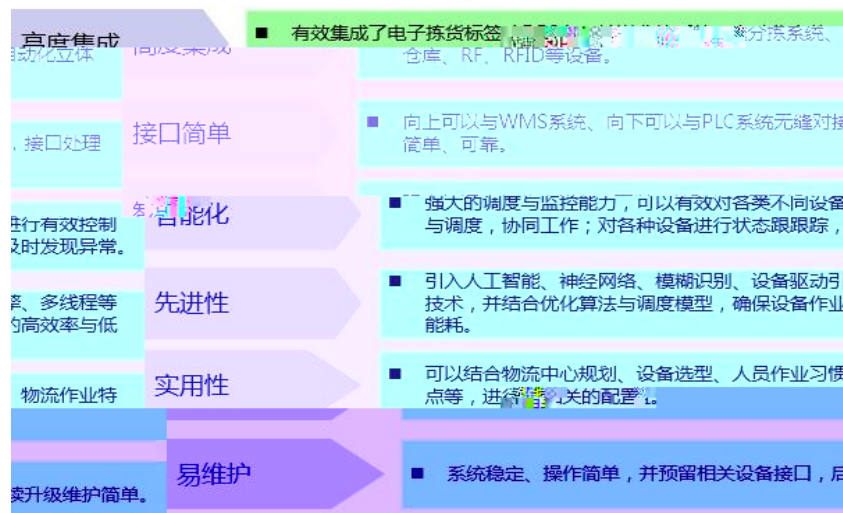
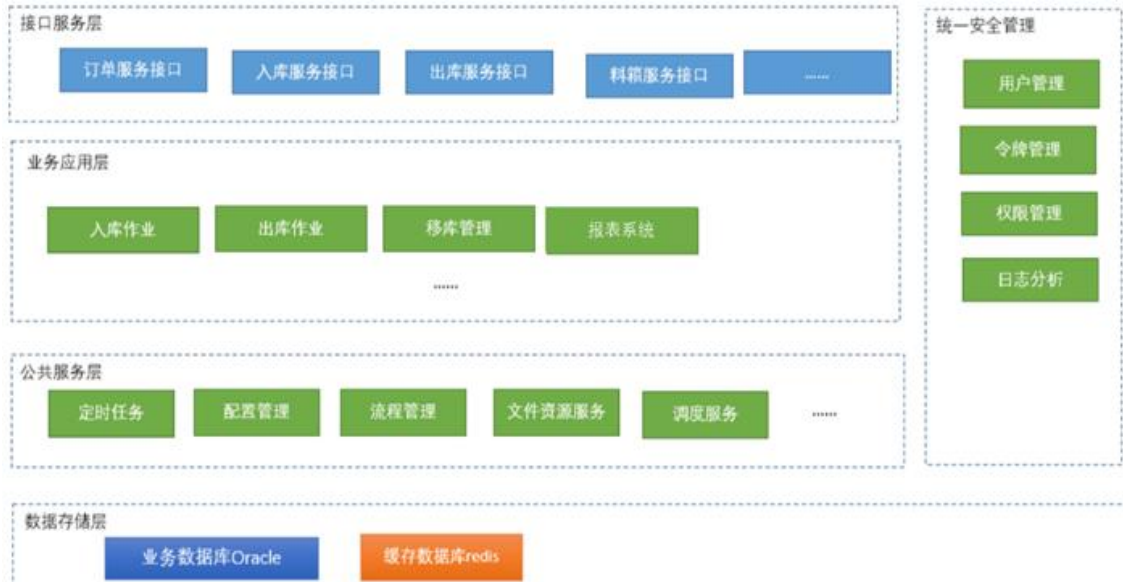

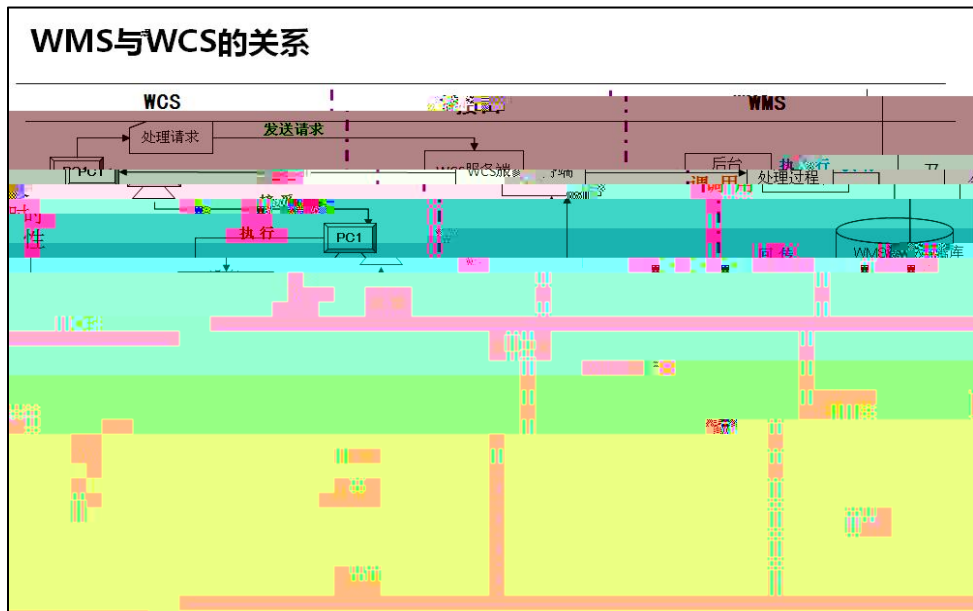
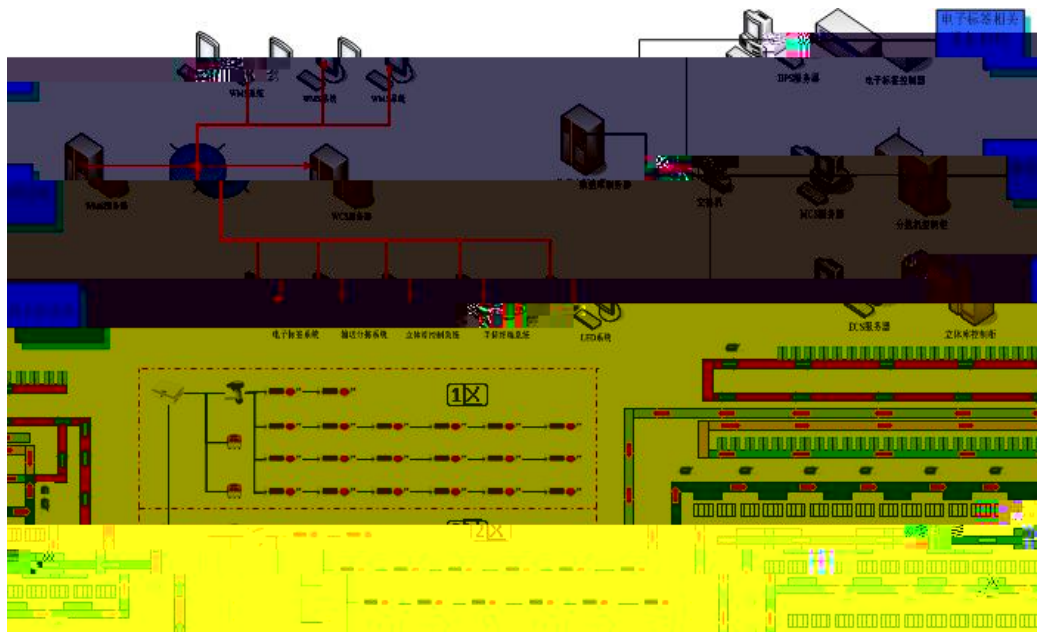



र|@

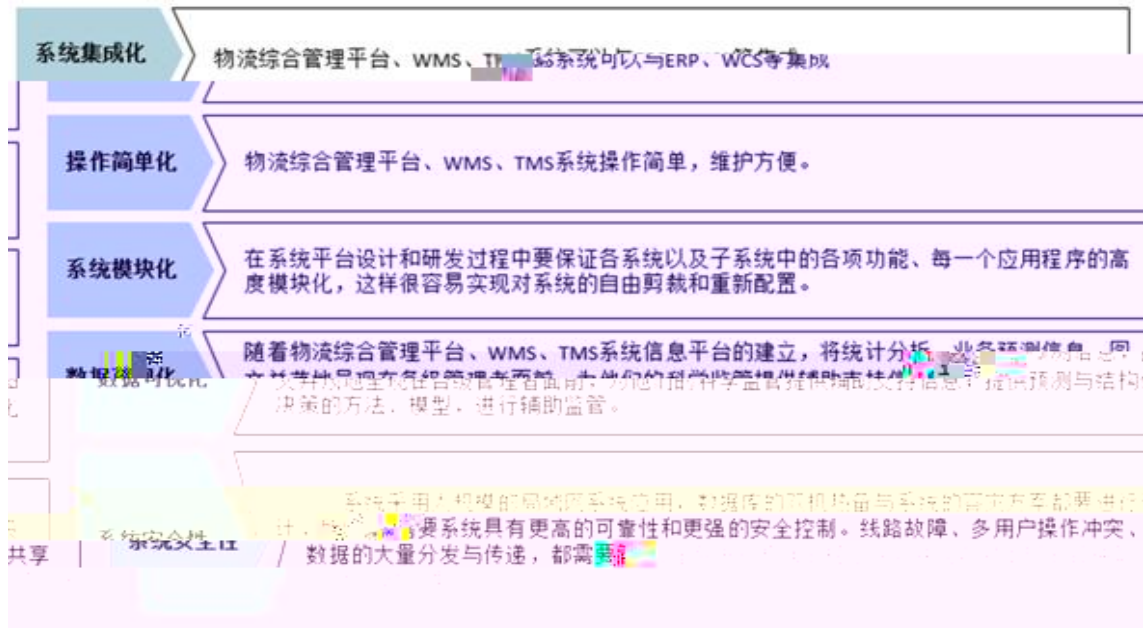





DEB

À 7 |

f *v* ~~fu~~ ~~fu~~

—

—

—

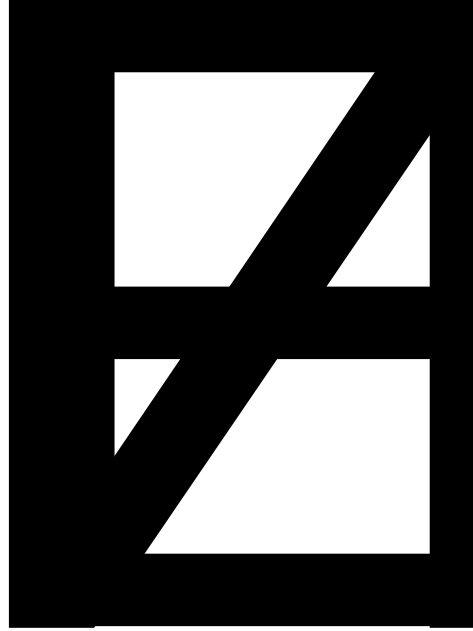

Ä

-

ø5d Z

©i V P p %!



1Ñ6é• § £3+...} O≠ 1Ñ6 £3+Ö _ ñÉ ñÉ...}™ “Q

质疑函范本

质疑供应商：

地址： 邮编：

联系人： 联系电话：

授权代表：

联系电话：

地址： 邮编：

质疑项目的名称：

质疑项目的编号： 包号：

采购人名称：

采购文件获取日期：

质疑事项1：

事实依据：

.....

法律依据：

.....

质疑事项2

.....

请求：

签字(签章):

公章:

日期:

